

STYRO STONE®

# Styro Stone Technical Manual

*including Guide to Local Authority National  
Type Approval (LANTAC) and Partnering Scheme  
for approvals under Building Regulations.*



**Styro Stone**  
[www.styrostone.com](http://www.styrostone.com)



**+800**  
International  
freecall

7  
PQRS

8  
TUV

9  
WXYZ

7  
PQRs

6  
MNO

7  
PQRS

8  
TUV

6  
MNO



## 1. GENERAL DESCRIPTION.

**1.01** Styro Stone is a method of construction known generically as “permanent insulated formwork” (PIF). In this method, the insulation material forms an integral part of the final structure. Styro Stones are open ended, hollow polystyrene blocks which fit tightly together to form a shuttering system. Concrete is poured into the hollow space to form a continuous wall. When cured, this wall supports the structural loads from floors and roofs, and the shuttering provides thermal insulation. Reinforcing steel is not normally required other than for lintels (see later).

**1.02** Building operations in the UK generally require approval under the Building Regulations. Styro Stone has been approved as a building system under the Local Authority National Type Approval Consortium (LANTAC). The approval applies to new dwellings having no more than three storeys plus a basement, and with floor areas not exceeding 300sm. This is effective for sites throughout England and Wales.

At the date of printing this Manual and Guide, a Scottish Type Approval Scheme (STAS) is being introduced. It is expected that Styro Stone will be approved under STAS, however, users should check the status with MK Associates (see below).

Northern Ireland, and the Isle of Man are not included in any Type Approval schemes and so application for approval to the Building Control Authority in those Regions must be made in the usual manner.

**1.03** Alongside LANTAC approval, Styro Stone has also entered a partnering agreement with Winchester City Council (WCC). This agreement is administered and managed by MK Associates (MKA) whose office is at 9 Rewlands Drive, Winchester, SO22 6PA, tel/fax 01962 881 624.

**1.04** In this Manual, all matters which relate to LANTAC and the Partnering Scheme, which must be complied with as a condition for the Schemes to apply, are printed in this type of text.

**1.05** Under the partnering agreement and for a standard fee, all applications for approval of building details in England and Wales should be sent in the first instance to MKA. Application forms and guidance notes for this purpose may be downloaded from the web site [www.styrostone.com](http://www.styrostone.com) <<http://www.styrostone.com>>, or requested from WCC or MKA. MKA in conjunction with WCC, will check the application in all its aspects, (not restricted to Styro Stone), and if compliant, will arrange for the plans to receive approval under the Regulations.

**1.06** The building details must comply with the Building Regulations “Approved Documents” (AD). Approved Document A (ADA) is concerned with structural stability. This is affected by vertical floor and roof loads, and by horizontal wind loads.

Wind loads vary according to site location and exposure, and there are limits on the sizes of unreinforced Styro Stone panels that can be used under the LANTAC type approval. If reinforcement is included within the concrete core (see later), then generally there will be no limitations on panel sizes for houses not exceeding two storeys. Appendix 1 includes an example of the procedure to be used for checking unreinforced panel sizes (which will be suitable for most

house designs) against the wind speed map.

Styro Stone can be used in panel sizes greater than those shown in Appendix 1, but these must be designed by qualified designers. MKA can arrange this service for an additional fee.

**1.07** Lintel loads vary according to the imposed (live) load, floor type and span. The Styro Stone system includes a special lintel mould, and Appendix 3 gives LANTAC approved tables of suitable lintel reinforcement for a range of openings and specified loadings. Abnormal floor loads, point loads from girder trusses and similar conditions, or opening sizes outside these limits require calculations by qualified designers. MKA can arrange this service for an additional fee.

**1.07** The building details must comply with ADL, which requires the energy efficiency of the structure(s) to be assessed. The assessment can be sent with the plans, or MKA can provide a SAP energy assessment for an additional fee. If MKA calculates the SAP for the design as submitted and it fails the requirements, MKA will advise the applicant, suggest and agree alternative details, alter the plans on behalf of the applicant and submit the revised plans to WCC together with the relevant SAP assessment.

**1.08** Following the submission of the plans under the Partnering Agreement, WCC will inform the Building Control Department of the particular Local Authority responsible for the site - the Inspecting Authority (IA). Winchester City Council will liaise with and inform the IA of all building regulation requirements and decisions. The IA will carry out the site inspections during construction. The partnering scheme includes liaison with the IA and provision of all necessary documentation, the builder needing only to notify the IA of commencement of work and to pay their local inspection fees.

**1.09** Agreed, standardised building details, and information relevant to type approval and the partnering agreement, are indicated (by this type of text) in this Manual and Guide. These details must be incorporated into the design in order to comply with LANTAC type approval. Compliance with type approval details will ensure that approval under the Building Regulations will be granted in respect of the Styro Stone details within the application.

**1.10** Applications for building regulation approval not made through the partnering scheme, must be submitted to the local authority responsible for the site. All such applications should be accompanied by a copy of the LANTAC System Approval Certificate (see later) and quote the certificate number SA-164-12-7021.

**1.11** In a conventional shuttering system, the shutters must be stripped after the concrete has set, and then any finishing layers would be applied to the concrete wall surfaces. In PIF systems, the shutter is left in place, permanently fixed to the contained concrete. The polystyrene forming the vertical inner and outer faces of the shutter provides insulation meeting the requirements of the Building Regulations ADL. The decorative internal and external finishes are then fixed over the polystyrene faces.

**1.12** PIF systems save the cost of transporting conventional shutters to and from the site, save the waste associated with cutting sheet material to size, and saves the cost of skilled labour erecting and

dismantling the shutters. Styro Stones can be assembled quickly using basic carpentry skills, waste is minimised and there need be no cost of removal from site. Transport cost to site of the shutter is also nil - because insulation is necessary, this cost can be allocated to the insulation process.

## 2. PHYSICAL CHARACTERISTICS

- 2.01** Styro Stone is produced under quality controlled conditions, which ensure consistency of its physical and chemical properties, including density, thermal conductivity and fire characteristics. This consistency is facilitated by using only virgin grade materials in the production processes.
- 2.02** Dimensional consistency and close tolerances are important. Styro Stone's upper and lower surfaces are castellated and rebated, and the vertical mating surfaces are tongued or grooved. When joined together, the fit is very tight and stable. This produces a shutter which is strong and inherently straight both horizontally and vertically, and able to contain the wet concrete, without leakage, at vertical and horizontal junctions.
- 2.03** The opposite faces of the Styro Stones are joined by slim, high density plastic wall ties. The ties fulfil two purposes. Initially they restrain the shutter faces from distortion during the concrete infilling process, and then they assist in permanently securing the insulation to the body of the concrete. These are also produced under quality controlled conditions, and are consistently and precisely located in each block. Their positioning and shape assists in the accurate location of any steel reinforcement required. Their size and shape do not interfere with the placing of concrete into the shutter void. Their thickness is approx 2.5mm, eliminating any risk of fire penetration.
- 2.04** The inner surfaces of the shutter have tapering grooves running vertically. These are to receive the wedge tongues of inserts used to form vertical stop ends around openings for doors and windows etc. *The stop ends are effective in reducing the possibility of cold bridges at these openings – ADL refers.* Their shape effectively anchors the reveals to the concrete core.
- 2.05** The outer surfaces of the shutter are grooved vertically at 50mm centres, aiding accurate cutting and trimming. The grooves also provide a key for render or the adhesive used to fix external brick slips or internal dry-lining finishes.
- 2.06** For design purposes, the density of the polystyrene facings is assessed at 30 kg/m<sup>3</sup>, the thermal conductivity (lambda value) is 0.035 W/m<sup>2</sup>K and the concrete core is assessed at 2400kg/m<sup>3</sup>.

In addition to the measured characteristics, Styro Stones have an assessed durability in excess of 60 years.

## 3. GENERAL DESIGN CONSIDERATIONS

(see Section 10 for approved LANTAC Design Details)

- 3.01** The design grid or module is derived from the basic Styro Stone unit. This is 1000 long by 250 high and 250mm wide. The thickness of the sidewalls is 55mm,

allowing for a 140mm mean width of retained concrete. The ends of the shutter are open, so that when shutter units are joined, the concrete is continuous. The internal faces are grooved to receive stop-end inserts. These are used to stop the wall and form the reveals at window and door openings. Grooves are provided at 25mm centres, and so wall lengths, and opening widths require a 25mm design module.

- 3.02** The faces are tied by integral wall ties, which restrain differential movement. These are staggered vertically and horizontally at 125mm centres; any reinforcing steel should be specified at this spacing, but see also 8.06 for design of links or stirrups.
- 3.03** The shutter ties have Vee slots at 30, 50, and 75mm centres from each shutter internal face. These slots will accommodate reinforcing steel up to 16mm diameter. Horizontal lintel, and internal and external wall reinforcement can be accurately located in these Vees, and vertical reinforcement can be tied accurately, ensuring correct spacing and cover.
- 3.04** Except for lintels, steel reinforcement in walls will normally only be required for earth retaining walls and basements, and for wall panel sizes larger than allowed at Appendix 1.
- 3.05** A 125mm depth lintel Stone is available to span over openings. This is used in conjunction with a 125mm half height Stone. This is the normal combination, and produces a lintel with an overall minimum depth of 250mm and brings the coursing back to level with the wall on either side of the opening.
- 3.06** The 125mm half height Stone can be used in conjunction with a 50mm height adjusting Stone to give any height to a multiple of 25mm; any finer reductions to the height can be had by careful trimming of the final lift beneath wall or roof plate level, or at the underside of the initial base course. Clearly adjustments should be avoided at intermediate lifts because the interlocking castellations will be lost.
- 3.07** Preferred design modules are thus 25mm horizontally and vertically.
- 3.08** Where a wall changes direction at 90°, special corner Stones may be used. Alternatively, and where a side wall butts up, the internal part of the shutter bridging the core is carefully cut away using a fine tooth saw. This maintains a continuous cavity and produces a monolithic, continuous concrete wall without transverse bridging.
- 3.09** Detailed dimensions of the different Styro Stones can be viewed on the web site at [www.styrostone.co.uk](http://www.styrostone.co.uk)

## 4. STRUCTURAL

- 4.01** If any part of a wall is to act as a retaining wall, it must be designed by a qualified designer. *Standard Styro Stone construction is mass concrete except at lintels spanning more than 1M, and under the LANTAC scheme, is subject to the restrictions on panel sizes and wind loadings shown in Appendix 1. All the Appendices and panel sizes comply with BS 8110 and ADA to ensure structural stability and durability. Appendices 1 and 3 show a range of panel sizes and reinforcement details suitable for most house designs. If the house design utilises panel sizes outside the*

prescribed range, or is sited so as to be subject to wind speeds greater than those permitted, the walls must be reinforced. Walls of houses with an overall height not exceeding 7.5m, may be reinforced with either T8 bars at 125mm vertically and horizontally using a minimum of 8 bars per panel in both directions, or with T10 bars at 250mm vertically and horizontally using a minimum of 4 bars per panel in both directions. This reinforcement will satisfy ADA and LANTAC at all sites in the UK excepting only those with extreme exposure conditions.

Houses with design features outside the parameters noted above must be designed by a qualified designer.

- 4.02** Designers should especially note the limitations within ADA regarding maximum unsupported storey heights and wall lengths, and maximum spans for different flooring materials; Appendices 1 and 3 take these limitations into account. There are also floor area limitations of 70m<sup>2</sup> for areas enclosed by four structural walls, and 30m<sup>2</sup> for areas enclosed by three structural walls. Houses with enclosed floor areas exceeding the ADA limitations must be designed by a qualified designer.

Appendix 3 provides a range of reinforcement details for lintels covering different spans and loading conditions. If lintels are required outside these ranges, they must be designed by a qualified designer.

- 4.03** When required, eg when acting as retaining walls, reinforcement should be specified at multiples of 125 or 250mm centres for both vertical and horizontal reinforcement. Styro Stones are produced to a range of standard sizes, but the effective sizes can be adjusted on site, within certain limits, see 3.06 above. It is preferable to adjust the design sizes slightly and thus accommodate the standard components, rather than make alterations to the Styro Stones.

## 5. THERMAL

- 5.01** Standard Styro Stones provide a mean concrete thickness of 140mm, and an insulation total mean thickness 110mm.

UK Building Regulations effective from April 2002 require walls to attain a minimum U value of 0.350 W/m<sup>2</sup>K; it is expected that this will be further improved to 0.300 W/m<sup>2</sup>K sometime during 2005

- 5.02** Allowing for internal and external surface resistances, the basic Styro Stone structure provides a U value of 0.312 W/m<sup>2</sup>K. Adding an internal finish of 12.5 mm thick wallboard fixed by dot and dab with a nominal air cavity of 5mm produces a U value of 0.296 W/m<sup>2</sup>K. Combining a 15mm external render with this internal finish produces a U value of 0.293 W/m<sup>2</sup>K and alternatively, an external brick skin with a 5 mm nominal air cavity in lieu of render provides a U value of 0.290 W/m<sup>2</sup>K

## 6. SOUND

- 6.01** Building Regulations require that walls separating attached dwellings shall resist the transmission of airborne sound. This requirement does not apply to detached dwellings.

The Regulation is satisfied by a solid concrete wall if it has a mass of 415 kg/m<sup>2</sup>. Assuming a normal concrete density of 2400 kg/m<sup>3</sup>, a Styro Stone wall alone provides a mass of 336 kg/m<sup>2</sup>. For terraced and multi-storey applications, the performance must be increased. For example:-

1. build two independent Styro Stone walls back to back along the length of the party wall or
2. provide a minimum 75 masonry skin to one side or
3. render, or fix plasterboard layers with staggered joints, to a density of 79kg/m<sup>2</sup> or
4. provide acoustic linings in accordance with manufacturer's instructions (design calculations must be provided to satisfy Building Regulations)

- 6.02** Where joists are built into the party wall, it is strongly recommended that the joists be staggered on either side of the party wall to prevent any possibility of the joist ends coming into contact with each other and forming a bridge.

Chasings for services should be as shallow as possible and staggered, as should electrical sockets and switches, to reduce possibility of sound penetration.

## 7. FIRE

- 7.01** Styro Stones contain a low combustion Type A flame retardant additive as defined in BS 3837 Part 1

- 7.02** When properly installed and protected by 12.5mm plasterboard fixed by dot and dab plus 9 mechanical fixings into the concrete core per 1.2m x 2.4m sheet, or render to BS 5262, or certain proprietary render and brick slip systems or masonry facing tied to the core at the rate of one per m<sup>2</sup> by stainless steel ties, an F 30 (0.5 hr) rating to DIN Standard 4102:1997 Part 2 is achieved. This provides a Class O finish to BS 476:Part, which does not affect the fire characteristics of the contained concrete wall.

- 7.03** The 140mm nominal thickness continuous concrete wall produced by Styro Stone provides a 90 minute fire resistance in the case of a wall exposed on one side.

If proprietary render or brick slip cladding systems are proposed, Building Regulation applications should include the relevant assessment details (BBA, Wimlass certification or similar) from the manufacturer.

- 7.04** If a cavity is required by the specified cladding system, approved cavity closures must be included at every second storey level and between every dwelling.

## 8. SITE CONSIDERATIONS – PRE POUR.

- 8.01** Styro Stones are normally delivered direct to the site from the factory. The Stones are shrink wrapped in packages which are light weight and easily handled by one person. When wrapped, the Stones are kept clean and are easily stacked. They should be kept wrapped until needed, and stored on their sides to protect the castellations from damage.

- 8.02** Shutter building normally commences off accurately levelled concrete strip footings, or a level concrete base slab. The surface of the foundation on which the shutter will be erected should be swept clear of all debris, and any cement laitance removed. If the slab is part of a basement below ground, or the wall is



designed as a retaining wall to withstand lateral loads, the bottom course of stones is laid over the starter bars, threading them between the tie gridwork. Any stop ends are inserted and cut-outs at changes of direction are made according to the design.

- 8.03** Cutting and trimming should be made away from the work before the Stones are fitted, to avoid polystyrene dust and off-cuts from getting into the shuttered void. The next course of Stones is then laid to a staggered bond, together with its necessary stop-ends etc. The second course and all subsequent courses must be tightly interlocked with the lower courses.
- 8.04** The strength of the polystyrene and the close dimensional tolerances of the Stones, becomes apparent as the interlocking of the courses progresses. The shutter forms an integrated, monolithic sheet structure, which will be seen to span from any high spots on the foundation. Any obvious pebbles can be knocked off to reduce the bridging effect, but it will normally be necessary to fill any gaps which appear between the bottom of the shutter and the slab with expanding foam. This is better than packing with mortar, which can form cold bridges. Care must be taken not to use too much foam, to avoid its intrusion into the shutter void.
- 8.05** Earth retaining walls and basements will normally be designed as reinforced concrete. The shutter ties have Vee slots at 30, 50, and 75mm from each internal shutter face. These slots will accommodate reinforcement up to 16mm diameter. Horizontal lintel, and internal and external wall corner reinforcement can be accurately located in these Vees, and vertical reinforcement can be tied accurately, ensuring correct spacing and cover.
- 8.06** *The positioning and fixing of steel stirrups or binders in lintels and other locations merits special consideration. The bottom main reinforcement should initially be placed to one side of its final location in order that the binders may be positioned; the main bars must then be threaded through the binders and tied to them. Space must be available to one side of the final location to allow for this. If space is restricted, it may be necessary to divide and splice the main reinforcement. The top main reinforcement, supported in the Vee slots of the Styro Stone ties, should be threaded through the binders and tied to them, so that the whole cage is suspended in the correct location. Binders should be dimensioned accordingly, with a vertical leg not less than 210mm.*
- 8.07** When erected, the shutter is rigid horizontally, but it remains flexible in the vertical plane along its length. It is also light weight and can be blown about on exposed sites, and disturbed by the flow of the concrete during the pour. It must be given the necessary stability by temporary bracing, at least until the concrete pour is completed. Bracing is best fixed before the wall is 2m high, and in any case before work ceases for the day.
- 8.08** Suitable bracing, incorporating horizontal supports for a working platform, is available for hire from Styro Stone. It is a simple adjustable L shaped brace, positioned at 2.5m centres maximum. The base of the shutter is aligned horizontally, and the bottom legs are bolted to the base slab. Final adjustments to ensure verticality are made by means of a turnbuckle which alters the angle between the legs of the brace. Checks on the horizontal alignment must be made throughout

the pour, and any adjustments made before the concrete stiffens.

- 8.09** A 125mm depth lintel Stone is available to form lintels spanning over openings. This is used in conjunction with a 125mm reduced height Stone to bring the coursing back to level with the walls on either side of the opening.
- 8.10** Styro Stone is fully re-cyclable, and offcuts and other waste can be donated to collectors. However, off-cuts and waste Styro Stone need not be taken off site to tip. Styro Stone is an effective insulator in below ground conditions and can be used to further reduce energy losses through the ground floor. This is done by cutting off the ties and placing the flat faces of offcuts against the external Stone faces below ground level, prior to backfilling, increasing the insulation thickness at those points. This is most effective when done to benefit the areas which will be most highly heated, such as the living room, or against the colder north or east aspects of the dwelling. This technique also reduces the disposal costs charged by the waste authority.
- 8.11** *It is strongly recommended that cutting and fitting of reinforcement, positioning of masonry wall ties, wall returns and stop ends, clearance of debris to ensure a clean cavity and all other preparation work be completed before the pour. When the pour commences, the rate at which the walls are filled will preclude all other work. If the pour is interrupted and cancelled part way through because the shutter is incomplete, expensive concrete and pump hire charges will be wasted.*

## 9. SITE CONSIDERATIONS – CONCRETE POUR

- 9.01** The concrete should not exceed more than 3m depth during the period whilst it remains in a fluid state. Under favourable conditions, and after the initial set has been achieved, the pour can be continued. It is not recommended that more than 5m depth of concrete be poured within a 24 hour period.
- 9.02** The concrete specified is a highly workable, free flowing mix. It is required to be self-compacting (but not self-levelling as this is normally too fluid a mix) because the shutter is not designed to withstand the stresses induced by vibrating pokers.
- 9.03** The infilling pour is best commenced at a location furthest from the pump. This ensures that the equipment can reach all parts, avoiding the possibility that the pour has to be interrupted whilst other equipment is brought to site. A flow restrictor should be used on the pump for the initial pour, and the reduced rate utilised around the entire perimeter of the structure. The initial pour should be restricted to 4-500mm in height, to give stability to the shutter. The alignment should be checked and adjusted as necessary before the main pour is commenced. The reduced rate of filling is maintained until the concrete has filled up approx one third of the height of the shutter. This will minimise the possibility of bursting caused by the vertical dropping of fluid concrete into the shutter. When the initial filling has reduced the height of the vertical drop, the restrictor can be removed, increasing the pour rate so that the wall is filled by the concrete flowing down the inside slump faces. Every slump face should be refreshed before each batch is exhausted, so that all faces have fresh

concrete, ready to receive the next batch. This will aid homogeneity of all walls.

- 9.04 At window and similar openings in the wall, the bottom horizontal run of Styro Stone is left open; the concrete is filled from either side and trowelled off level in the opening. The pour is then continued elsewhere to allow the concrete at the bottom and sides of the openings to stiffen. When this has happened, the pour can be resumed and the lift continued either side of the opening.
- 9.05 As the pour proceeds, the alignment of the shutter must be checked continually. Adjustments can be made provided the height and therefore the weight of the concrete contained at the point of adjustment is not too great. Adjustments can be made using a heavy hammer and a stout timber bolster on either face of the shutter, in conjunction with adjustments to the turnbuckles on the braces.
- 9.06 Long openings are normally stopped off, and the opening left vacant of any Stones. In these cases, lintels must be propped during the pour. This is easily done by using offcuts from waste blocks, stacked vertically within the opening, to form props.
- 9.07 If freezing weather or heavy rain is expected after completion of the pour, the top surface of the concrete must be protected with sacking. The insulation provided by the PIF shutter ensures that additional cold weather protection is not required to protect the vertical faces.
- 9.08 Day joints between pours should be prepared by washing and brushing away any cement laitance as soon as possible after the initial set, to expose the aggregate. This will ensure a good bond with the following pour. Horizontal day joints are best located approx 50mm down from the top of the Stones. This will keep the castellations clear. Any concrete spilled into the castellations should be washed away before it sets.

## 10. DESIGN DETAILS

- 10.01 *The LANTAC approved details are applicable to detached dwellings only. This LANTAC approved system is for load bearing panels of un-reinforced concrete within the sizes and site exposure conditions noted in the Appendices. Panels within these sizes but on sites outside the exposure conditions must be reinforced in accordance with 4.01.*

*Panel sizes greater than those shown, irrespective of exposure conditions, are within this approval provided they incorporate reinforcement designed by a qualified designer; it is recommended that such applications be made via the Partnering Scheme.*

***It should be noted that if a ground bearing slab and separate strip foundations are used, discontinuities in the DPC may occur. On sites where gassing of radon is a possibility, the recommendations within BRE document BR 211 (1999), "Radon - Guidance on Protective Measures for New Buildings" must be followed. On sites where gassing of methane is a possibility, the recommendations within BRE document BR 212 "Construction of New Dwellings on Gas-Contaminated Land" must be followed. The suspended floor detail will best produce a***

***robust and continuous water and gas seal. The actual choice will be influenced by the bearing strength of the soil.***

*If internal masonry walls are required to act as buttress walls, they should be tied directly to the concrete core of the external Styro Stone walls after removing the layer of polystyrene along the abutment face.*

- 10.02 *Concrete must be specified as pump grade, C25, 300 kg/m<sup>3</sup> cement content and water cement ratio not exceeding 0.7; slump must be 75-125mm, and recommended aggregate size is 10mm. This specification is aimed at ensuring the Styro Stones are completely filled during the pour without the need for vibration equipment, and should be used even when placing is undertaken by hand instead of pumping.*
- 10.03 *Foundations are normally built off concrete strip or slab - see details following. If stepped foundations are needed, the steps should be in multiples of 250mm to co-ordinate with the Styro Stones. Builders have several options, with insulation either above the slab for rapid responses to changing heating demand, or below slab for high thermal mass:*

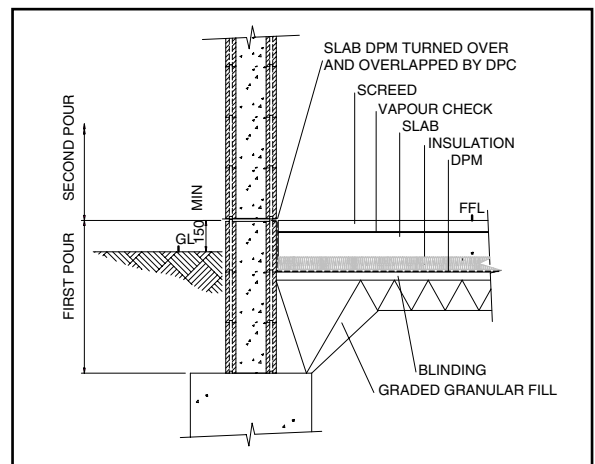

Fig 1

- 10.04 *Fig 1 uses Styro Stones from top of foundation strip to the general level of a ground bearing concrete slab with insulation positioned beneath the slab and above the dpc. The first pour using standard grade concrete is restricted to this lift only. The Stones should be set out from each corner, restricting the use of any part blocks to the central run of the wall, and inserting any void formers, service entry ducting etc into each course before laying the next. The surface of the first pour is trowelled level and smooth. After the first lift has cured and the slab cast, the slab dpc is turned over the trowelled surface and a traditional or liquid dpc suitable for use with polystyrene (applied strictly in accordance with the manufacturer's instructions), is applied to the trowelled surface, above the turned over section of slab dpc. This provides a continuous moisture barrier as required by ADA. The next lift of Stones is positioned following the same principles as for the first lift, and the concreting operation is resumed, again using standard grade concrete.*

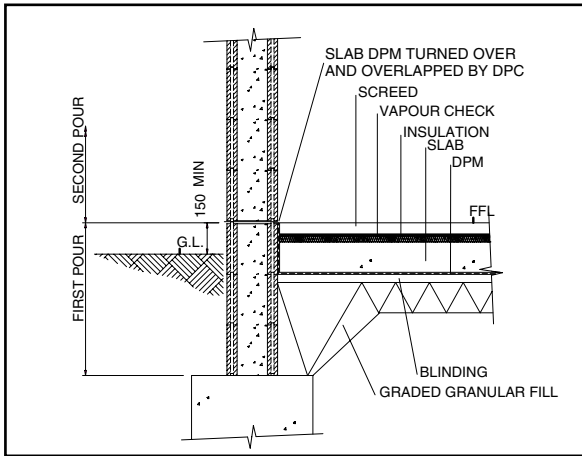

Fig 2

10.05 Fig 2 shows a similar detail, but with the slab insulation positioned under the screed or other finish, and above the dpc and concrete.

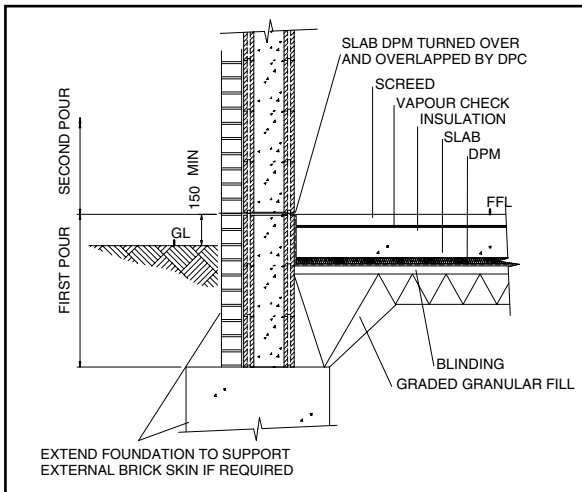

Fig 3

10.06 Fig 3 indicates how an un-reinforced toe extension may be formed on the outer edges of the raft foundation, onto which either Fig 1 or 2 may be constructed. The toe may be further extended to support a brick outer facing if required.

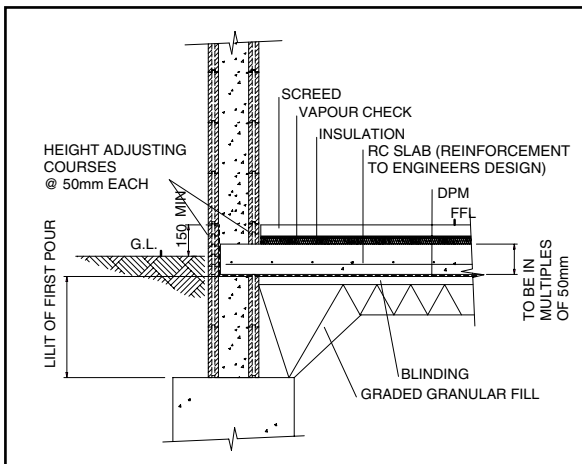

Fig 4

10.07 Fig 4 shows an in-situ suspended ground floor slab

with insulation above the slab. If Styro Stones are used for the first lift from the foundation strip, the first pour is stopped at the underside of slab and trowelled smooth. After curing, the dpc is laid oversite to receive the slab, and dressed up over the edge Stones, or the Styro Stone height adjusters (each 50mm high) on the outer face. The slab is then poured. After the slab is set, the wall is raised to the next lift following the same principles as for the first lift, and the concreting operation resumed, again using standard grade concrete. The slab thickness should be designed to multiples of 50mm to course with any height adjusting Stones.

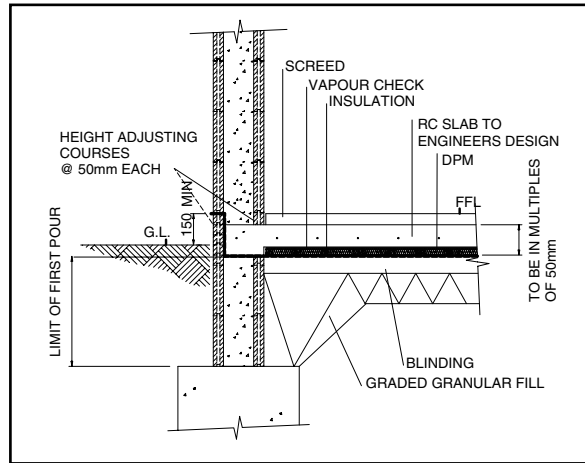

Fig 5

10.08 Fig 5 shows a similar suspended slab, but with the insulation positioned below the slab. In this case, the overall slab and insulation thickness should be designed to multiples of 50mm to course with any height adjusting courses.

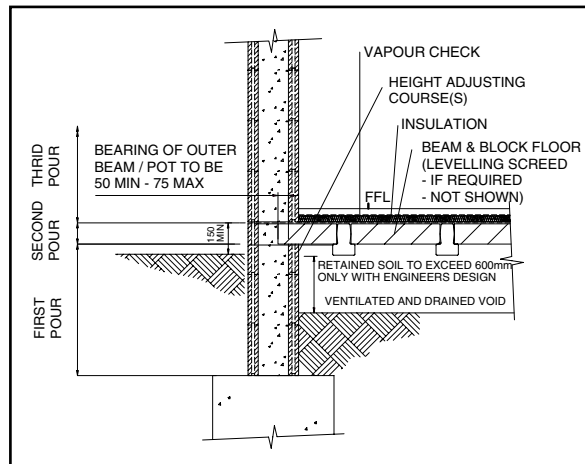

Fig 6

10.09 Fig 6 shows a pre-cast beam and lightweight pot ground floor, with insulation above. If Styro Stones are used for the initial lift off the foundation, height adjusting courses and expanding foam are used on the inner face to close the gap (if any) between the undersides of beam and pots. The first pour is stopped and levelled at the underside of beams. After curing, the floor is placed in position and a second pour is made, trowelled smooth and finished at the upper surface of the floor. After curing, the dpc is positioned and the wall raised to the next lift, again using standard grade



concrete. The beam and pot floor thickness should be selected to multiples of 50mm to course with the height adjusting courses. If satisfactory propping of the beams can be arranged, stones can be trimmed to around them, and the initial lift terminated just below the upper floor surface, thus building-in the floors with the walls.

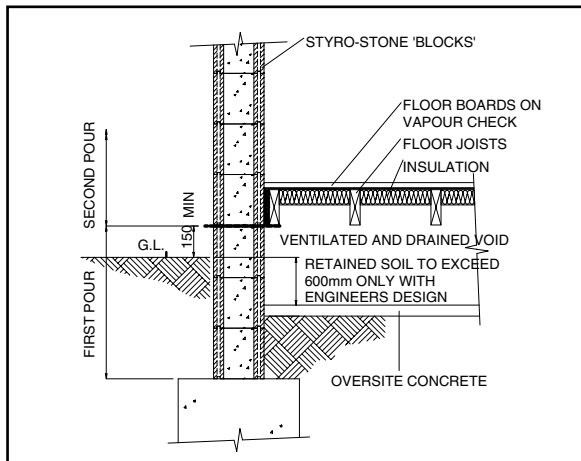

Fig 7

**10.10** Fig 7 shows a suspended timber floor, with flexible insulation between the joists; the wall detail is valid for rigid insulation above the joists. The method of construction is similar to Fig 6 except that the Styro Stones are easily trimmed to fit around the joist ends. Adjusting courses are therefore not required. Cut ends of joists must be treated with a non-bituminous waterproofing agent and positioned so as to terminate at the centre of the concrete core.

**10.11** Vee Tec Beams are available from Styro Stone (UK) Ltd. The Vee Tec Beam system normally incorporates insulated infill sections instead of concrete pots. When specified by a qualified designer, Vee Tec floors provide clear spans up to 14m. Installation details are similar to those for conventional beam and pot floors

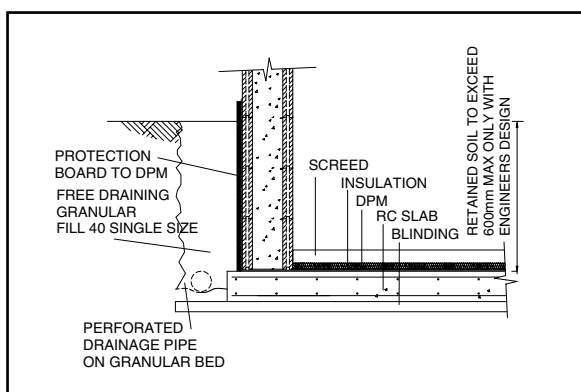

Fig 8

**10.12** On sloping sites, it may be preferable to excavate to a standard level rather than step the foundation, and form a semi-basement (restricted to non-habitable, Grade 2 classification, suitable for garages, plant rooms and storage purposes) on the uphill section – see Fig 8. Styro Stone may be used in this situation provided that the height of retained earth does not exceed 600mm. It is also necessary that normal ground water level is below the underside of the foundation,

the soil type is chalk or sandy gravel, and the subsoil drain and free-draining backfill is positioned as shown, reducing the likelihood of raising of the water table during prolonged rainfall and hydrostatic pressure. Styro Stone retaining walls may be used to retain heights greater than 600mm when designed by a qualified designer.

**10.13** Service openings for water, drainage, electricity, gas, and telecoms should be formed before concreting any lift. It is recommended that a sleeve with an external diameter equal to the service duct diameter + 50mm clearance is inserted into the Styro Stone at the intended level and orientation of the service. If waterproofing and protection against gassing is required, it will be necessary to seal the service entry through the sleeve (see Approved Document “Basements for Dwellings” Fig 2A.9 for appropriate details). Service openings above ground level must be formed and sealed using non-combustible materials.

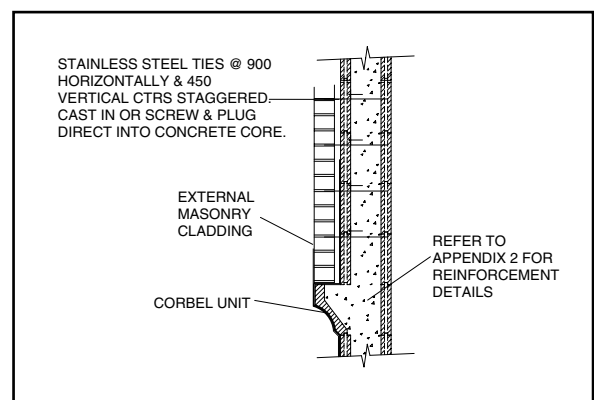

Fig 9

**10.14** Masonry cladding should be fixed as closely as possible to the outer face of Styro Stone. If the cladding, eg stonework, varies in thickness, a nominal space of 5mm or so should be allowed between the inner face of the cladding and the Stones. This will enable the external face to be plumbed. This tolerance gap should be filled with mortar as the masonry is raised, and fully flushed with mortar at least at every sill location and at every storey level. Stainless steel wall ties, which secure the cladding to the concrete core, are best placed in position before the concrete is poured. They are pushed through the outer face, across the core cavity, and into the opposite inner face of the Styro Stone blocks. The ties should be horizontal, or slightly inclined downwards to the external face. The ties must be located at a maximum of 900mm horizontally and 450mm vertically; at openings they must be located within 150mm of each opening and spaced 300mm vertically. Ties should be positioned before the filling is commenced. Ties supplied by Styro Stone are specially designed to be positioned correctly and to remain in position, undisturbed during the concrete pour. If prior positioning cannot be done, they should be pushed into the concrete as soon as possible after pouring and in any case before the initial set is attained. Insertion of other tie designs is facilitated by first cutting through the outer insulation at each location with a sharp blade.

Where the foundation depth, and area of masonry below ground, is a minimum, the cladding should be raised from an extended strip or raft foundation. The footing should be widened by an amount equal to the width of the cladding material plus 50% see Fig 3.

Where the foundation depth is excessive, special Styro Stone boot lintel or corbel blocks can be used – see Fig 9. The standard concrete mix is reinforced to LANTAC approved details which may be used to support cladding heights up to 7.5m – see Appendix 2 and Table.

**10.15** Under normal service conditions, the mass concrete superstructure walls are protected from wide temperature ranges, internally and externally, by the insulation layers, and expansion joints are not normally necessary. However, joints should be considered in abnormal conditions and on walls longer than 9.0m.

**10.16** Window and door openings are formed using 50mm thick stop ends inserted within the Styro Stones. The openings are then carefully cut out using a fine tooth saw or hot wire cutter, and the frames fixed through the stop end inserts by means of normal frame fixings, drilled into the concrete core. Fixings must be at not less than 600 centres, with at least two fixings per jamb. Fixing through the insulation ensures there is no cold bridging. Frames should be specified with a 5mm clearance, and this gap must be filled with expanding foam after mechanical fixing.

When external render is specified, the gap between the external frame junction with the Styro Stone must be sealed, before the render is applied, with a self adhesive, moisture sensitive expanding tape gasket, and the return render weathering detail around the jambs, head and sill must be in accordance with Fig 10 and 11. External jambs are recommended to be at least 100mm deep. After the render has cured, a second seal of mastic must be applied to the external frame junction with the render.

When external masonry cladding is specified, frames should be positioned to protrude so as to cover the junction between the inner face of cladding and Styro Stone. A self adhesive, moisture sensitive expanding tape gasket must be applied to the outer portion of the frame/Styro Stone junction, followed by a final mastic seal between frame and cladding in accordance with Fig 12. Note that a vertical dpc is not required.

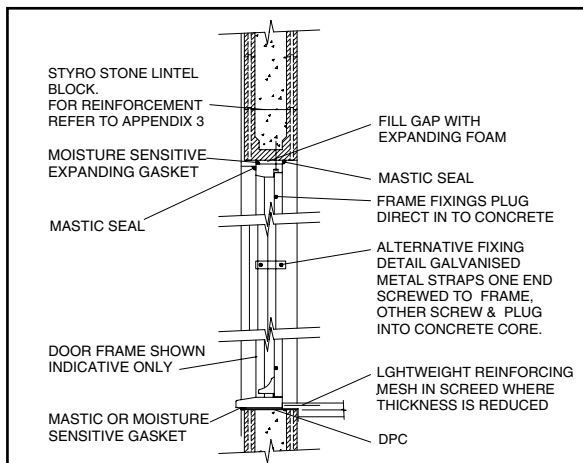

Fig 10

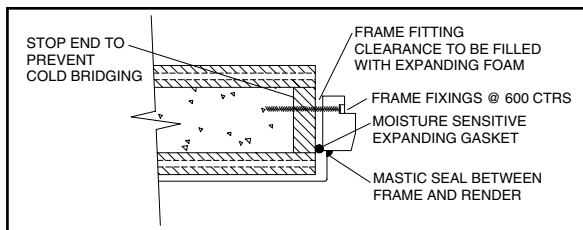

Fig 11

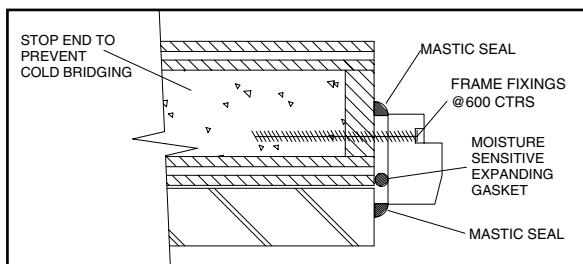

Fig 12

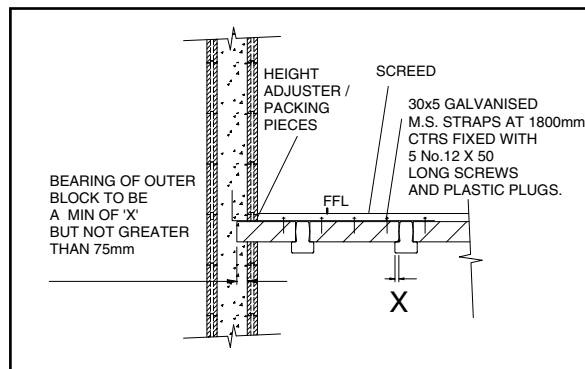

Fig 13

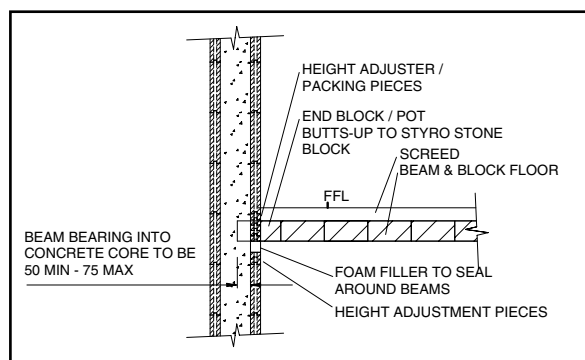

Fig 14

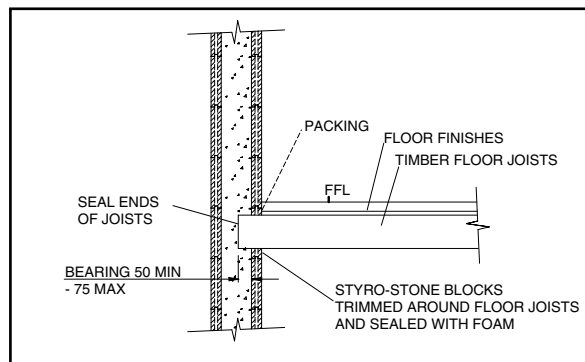

Fig 15

**10.17** Upper floors do not have the complication of dpc's or gas control membranes required for ground floors. Joists, and beam/pots are easily supported during construction and any props removed afterward. Consequently, both timber and concrete floors are normally built-in with the pouring operation, the ends of timber joists being first treated with a non-bituminous waterproofer.

The joists are propped to the required level and centres, and positioned to protrude into the core by 50mm min, 75mm max, see Figs 13, 14 and 15. The Styro Stones are carefully trimmed on the inner face to fit closely around the joists, any gaps being sealed with expanding foam. The next 3.0m lift from the ground floor is continued to finish just above the top of the joists or beams. This fixes the floor and minimises concrete wastage because the actual termination level is not critical. Terminating the pour just above the top level of the floor is done to minimise any possibility of concrete bursting through, where the Stones have been trimmed to fit around the joists etc. The pour to the next floor or eaves level is continued after curing.

If propping is not convenient, the lift from the ground floor can be terminated 25-40mm below the underside of joists and allowed to cure. The joists are then set to the required centres and levelled on strong mortar pads 25-40mm thick. The Styro Stones are then carefully trimmed around the joists, filling any gaps with expanding foam, and the pour continued. A restricted rate pour should first be made around the perimeter, limiting the height to 300 to 400mm until the concrete stiffens, to reduce the risk of bursting.

**10.18** Galvanised metal lateral wall restraints are required where joists run parallel to the external walls. They should be placed at 1800mm centres unless otherwise specified by a qualified designer. Because of the filling sequence of operation of the Styro Stone system, the straps are turned upward in the centre of the cavity (rather than vertically downward as normal) and are fixed in the wall during the following pour – see Fig 13

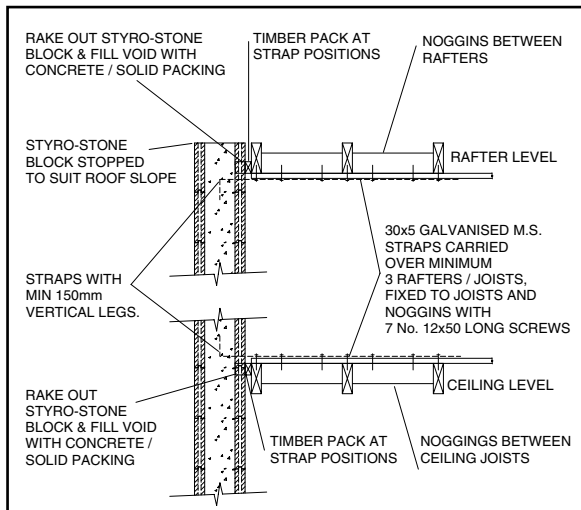

Fig 16

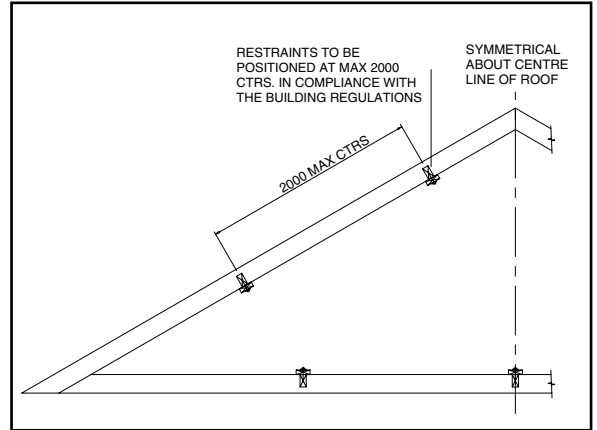

Fig 17

**10.19** Roofing wall plates are held in place by galvanised rag bolts, cast in at 2.0m centres, or with resin anchors, or expanding bolts drilled and set afterwards.

Roof trusses are restrained by galvanised straps at 2m centres. The truss legs must be long enough to pass through three trusses, and are fixed to the underside of the rafters, or to the top of the ceiling joists. The wall leg may be either cast in a minimum of 150mm or screw fixed to the core (after removing a strip of Styro Stone from the inner face) at 100 centres using 2 no. 50 x 6 rust resistant screws.

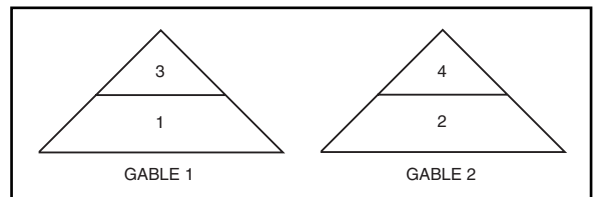

Fig 18

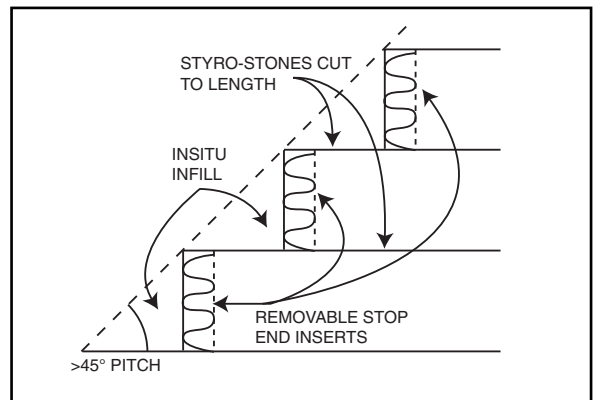

Fig 19

**10.20** Gable ends are formed by carefully trimming the Styro Stones to the required slope and concrete filling in the sequence shown in Fig 18. By following this sequence, the concrete is enabled to stiffen before filling, allowing stages 1-4 to be trowelled to the final slope before filling stages 5-8 in a similar manner.

Where gable ends are pitched at angles greater than approx 45°, it may be preferable to use an alternative method. Stop end inserts may be used to create a

stepped gable, corresponding to the required slope, which is first filled – see Fig 19. When the concrete begins to stiffen, the inserts must be removed (if left in place, they will weaken the wall where the truss restraints are to be located) and the voids filled either with cut masonry blocks and cement mortar, or with concrete which was set aside during the main pour and allowed to stiffen sufficiently to remain in place after shaping, without slumping.

- 10.21** Finishes may be conventional wet render and plaster set coat, or plaster board dry lining fixed by dot and dab adhesive plus mechanical fixings. If dry lining is used, the fixing must be strictly in accordance with the manufacturer's instructions. Particular attention is required regarding the continuity of wall lining from finished floor level to the underside of ceiling, and the provision of a continuous bead of adhesive horizontally at floor and ceiling levels. In order to ensure a Class O rating, dot and dab fixing must be supplemented by mechanical fixings as noted previously.
- 10.22** Perforations in dry linings, eg around fireplace openings, must include a continuous bead of adhesive around the perforation to prevent combustion gases leaking into the dry lining cavity.
- 10.23** Boiler flues and casings must comply with Approved Document J (ADJ) and in particular with the minimum distance "X", referred to in ADJ, which must be supplied by the specified flue/boiler manufacturer. Styro Stone is required by ADJ to be protected and separated from open fires, hearths and free standing heating appliances by incombustible materials. Where such appliances are specified, designs must have regard to the requirements in ADJ.
- 10.24** Styro Stone construction method, when used in conjunction with concrete ground floor slabs, produces homes which are more than usually draught free. Designers should consider the provision of controllable ventilation systems.
- 10.25** The preferred method of installation of electric cables is for surface mounting onto the Styro Stone and then to be dry-lined over. This avoids the possibility of overheating, which can occur when cabling is installed in chases within insulating materials. To counter overheating, the IEE Regulations require cable sizes to be increased, wherever cables are run in chases within insulation, which are to be covered over. The Regulations should be followed whenever this is intended. Direct contact between pvc covered cables and polystyrene should be avoided; migration of plasticiser may occur, which can lead to the embrittlement of the pvc cable covering

## **APPENDIX 1**

*Maximum panel sizes and site location map.*

*The capability of un-reinforced mass concrete walls to withstand stresses caused by wind is influenced by the wind speeds likely to occur on the chosen site, the size of the wall panels and any openings in them (for windows etc), and vertical loading. Increasing vertical loads generally enable the panels to withstand higher wind loads. The vertically loaded panel sizes assume a roof span of 10.0m and floor spans of 4.5m; houses which vary significantly from these assumptions may need a qualified designer. Wind speeds vary around the country, and sites are further influenced by local factors such as height, distance from large areas of open water, and whether in sheltered urban locations or more exposed rural countryside.*

*If Building Regulation approval is sought via the Partnering Scheme, this site information must be provided by completing the Site Information Form; these details will be used to check the applicability of the LANTAC maximum panel sizes.*

*An external wall panel length is the distance between the return ends or internal butting walls providing structural support. Storey heights are measured between floor joist centres. Panels within the following LANTAC size limits, but on sites where the wind speeds exceed those allowed, comply with LANTAC if they are reinforced in accordance with 4.01*

*Panels outside the LANTAC size limits will always need to be designed by a qualified designer.*

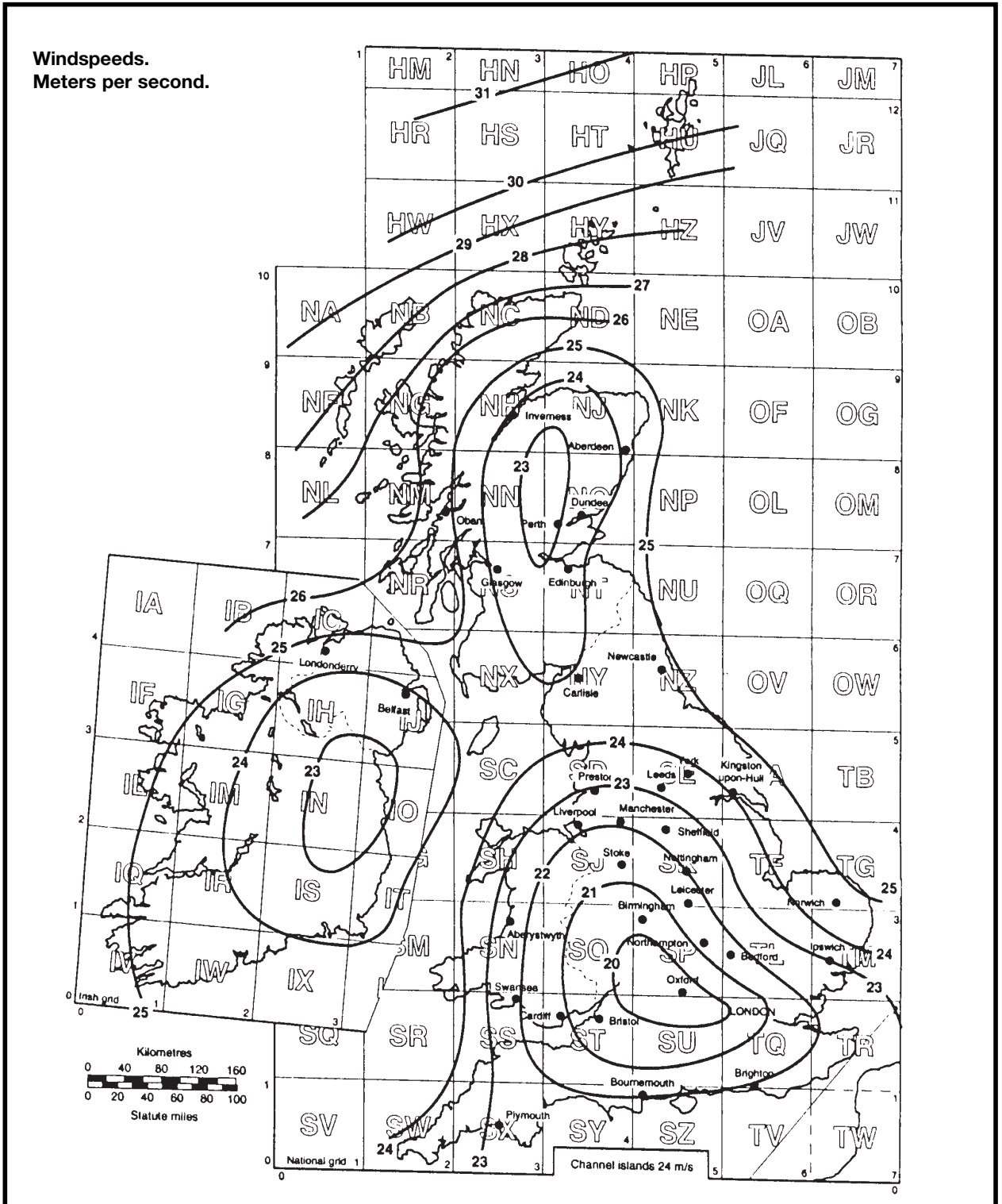

Reproduced by permission of the Building Research Establishment Ltd



Table 1-allowable wind speeds, **towns\***

Altitude (m)	Distance to open water (km)				
	1.0	20	40	70	100
25	27.22	28.78	29.24	29.91	30.57
50	26.57	28.09	28.54	29.20	29.84
75	25.95	27.44	27.88	28.52	29.15
100	25.36	26.82	27.24	27.87	28.49
125	24.80	26.22	26.64	27.25	27.85
152	24.22	25.61	26.01	26.61	27.20
230	22.68	23.98	24.36	24.92	25.48

Table 2-allowable wind speeds, **rural\***

Altitude (m)	Distance to open water (km)				
	1.0	20	40	70	100
25	22.61	23.92	24.31	24.82	25.38
50	22.08	23.35	23.73	24.23	24.78
75	21.56	22.81	23.19	23.67	24.20
100	21.07	22.29	22.65	23.13	23.65
125	20.60	21.79	22.15	22.61	23.13
152	20.12	21.28	21.63	22.08	22.58
230	18.84	19.93	20.26	20.68	21.15

\*site not near steep slopes; upwind distance to edge of town less than 0.1km. See Site Information Form for other restrictions.

Step 1 check altitude of site (from OS Landranger map 1:50,000); read from Table allowable wind speed for site and compare with wind speed map. If within allowable limits, go to Step 2. If not, go to Step 3.

Step 2 compare design panel sizes with following allowed sizes:

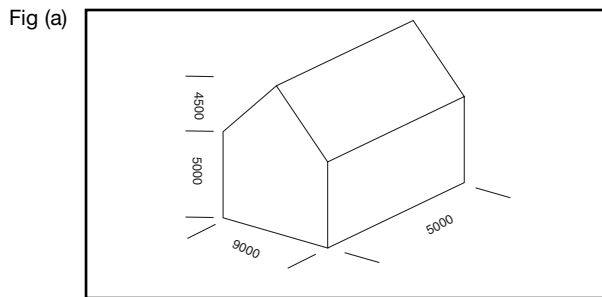

Walls with no vertical load or openings.

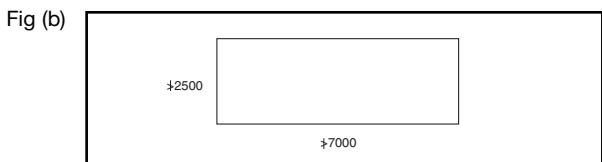

Vertically loaded wall panels, no openings. Support conditions: bottom or sides continuous, top simple @ joist bearing.

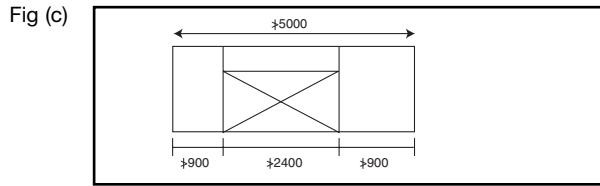

Single large opening eg Patio door. Wall vertically loaded or no load. Support conditions: bottom continuous, top simple ends continuous.

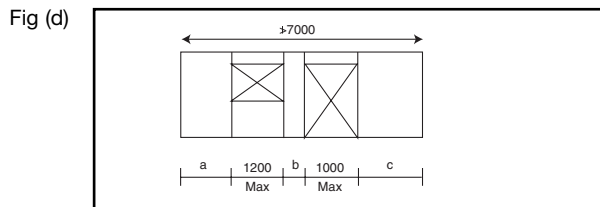

Window plus door opening. Loading condition varies - see table. Support conditions: bottom continuous, top simple, ends vary - see table.

End support condition	Vert Loading?	a	b	c
Continuous, both	Yes	≤950	≤900	≤950
Continuous, both	No	≤950	≤900	≤950
Simple, both	Yes	≤1500	≥1800	≤1500
Simple, both	No	≤1500	≥1800	≤1500

If all panels are within allowable sizes, apply for Building Regulation approval under the LANTAC and Partnering Schemes. If any panels exceed the allowable sizes, refer to designer and include calculations and reinforcement details with the application.

Step 3 compare design panel sizes as shown in Step 2. Any panels not exceeding the allowable sizes must be reinforced in accordance with 4.01

If any panels exceed the allowable sizes, refer to designer and include calculations and reinforcement details with the application.

**APPENDIX 2**

corbel reinforcement to carry masonry cladding max 10.5m high

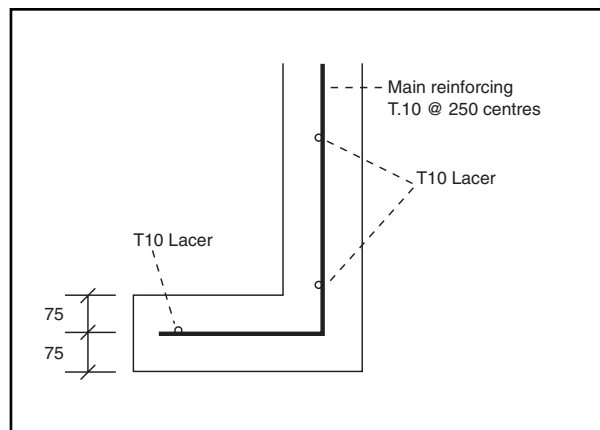

**APPENDIX 3** Lintel reinforcement for standard domestic floor loads

Reinforcement over openings						
Location	Span (m)	Loadings kN/m (Ultimate)	Reinforcement			Comment
			T	B	Links	
Eaves	<1.0m	17.0	none	none	none	Minor openings only
Eaves	2.2m max	17.00	2T10	2T10	R8 @ 125c/c	Roof Span taken as 10.0m
	1.0m min		none	2T10	none	
*	2.3m max	24.00	2T16	2T16	R8@125c/c	Timber floor, span assumed to be 4.5m
*	<1.0m	24.00	2T10	2T10	R8@125c/c	Timber floor, span assumed to be 4.5m
*	1.9m max	36.60	2T16	2T16	R8@125c/c	Concrete floor, span assumed to be 4.5m
*	<1.0m	36.60	2T16	2T16	R8@125c/c	Concrete floor, span assumed to be 4.5m

\* Lintel supporting load bearing floor joists or beams



**Local Authority**  
**BUILDING CONTROL**

---

**NATIONAL TYPE APPROVAL**

**SYSTEM APPROVAL CERTIFICATE**

Certificate No: SA-164-12-7021

Date: 22/08/02

---

**1 Certificate holder**

Name: Styro Stone UK Ltd

Address: Europa House 16A High Street Tenterden Kent TN31 6UH

Tel: 01580 767 707

---

**2 System Title**

Description: Styro Stone Permanent Insulated Formwork

---

**3**

The system has been assessed on the following drawings and documents:

Styro Stone Technical Manual.

---

**4 Assessment**

The design and method of construction of the system described in (2) above has been examined and as far as it has been shown has been found to be capable of complying with current Building Regulations.

---

**5 Conditions of certification**

- 1 The design shown and the materials specified shall not be changed without reference to the local authority responsible for certifying the system.
- 2 The certificate shall be valid for three years or until invalidated by formal notice.
- 3 Where reference is made on a plan to any Code of Practice, British Standard or manufacturer's instruction it shall be construed as a reference to such publication in the form in which it is in force at the date of this certificate.
- 4 This certificate should not be regarded as a formal approval under the Building Regulations.

---

**6 Authority**

This system approval certificate is authorised by:

Name: P. CHILVERS Signature: P. Chilvers

on behalf of: Winchester City Council

---

A SERVICE OF THE LOCAL GOVERNMENT ASSOCIATION

**STYRE STONE®**

[www.styrostone.com](http://www.styrostone.com)